



PDSK 40

PDSK 50 PDSK 80

# POWDER PUMP

SKYLINK Pneumatic Diaphragm Pump



Easy to install



Easy to move



High reliability

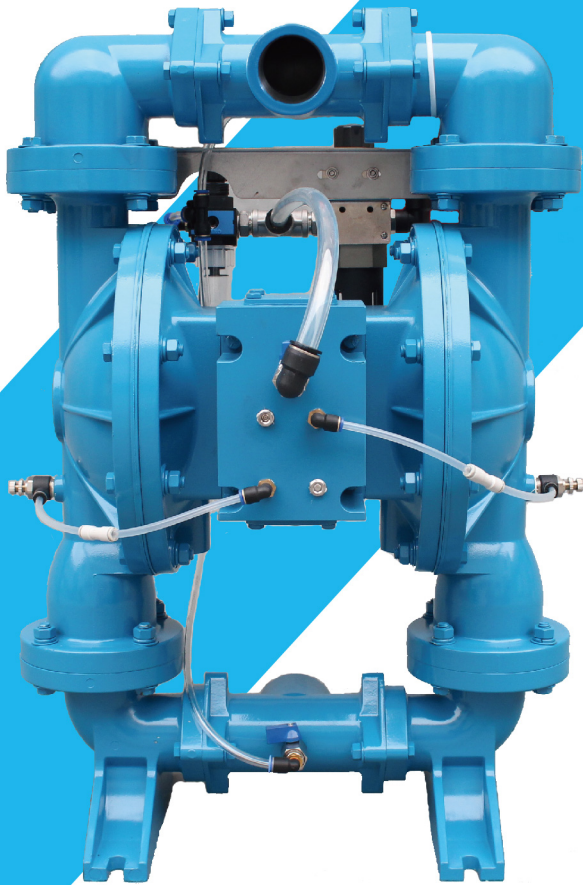

# INTRODUCTION

## Operational Principle ● ● ●

In two symmetrical cavity diaphragm pump, each equipped with a flexible diaphragm, a connecting rod two diaphragm form one, the installation of two position five way valve in the air inlet, the compressed air from the intake pump into the intermediate joints, the diaphragm two working chamber, the diaphragm synchronous motion driving rod connection. At the same time, the gas in the other working chamber is out of the pump from the back of the true diaphragm. When the piston reaches the end of the stroke, the valve train automatically introduces compressed air into the other working chamber to drive the reverse movement of the diaphragm pump, so that two diaphragm's synchronous reciprocating motion is formed. There are two one-way ball valves in each working chamber. The reciprocating motion of the diaphragm causes the volume change in the working chamber, forcing the two one-way ball valves to turn on and off alternately, so as to continuously enter and discharge the powder.

Through technology improvement, skylink integration without stall with the new valve, air distribution induced fluidization system, not only improve the transmission efficiency, and effectively prevent the suddenly blowout of powder at the moment of start-up. The flow of gas and driving gas supply, with 2 air supply air pressure interlock protection function, can effectively prevent the gas supply pressure is not consistent with the damage to the powder pump.

## Features of Product ● ● ●

**01** Easy to install, portable, high reliability, Ideal new powder conveying equipment with low failure rate

**02** Suitable for small batch, Powder addition at low elevation



## TECHNOLOGICAL SUPERIORITY

SKYLINK Pneumatic Diaphragm Powder Pump is designed with the latest valve principle, and the following are its technical advantages:

- Non balanced valve, no dead point, low pressure start;
- External valve design, fast and reliable, reversible, maintenance without the need to open the pump body;
- Anti icing and quick exhaust;
- The intermittent high efficiency flow induced flow system is used to optimize the proportion of gas / material, reduce the gas consumption and the gas - solid ratio of the material.
- Instead of the inefficient manual powder delivery method, it is directly applied to the production process to reduce air pollution and waste of raw materials.
- Instead of the inefficient manual powder delivery method, it is directly applied to the production process to reduce air pollution and waste of raw materials.
- Fluidized gas and driving gas can be separated to avoid oxidation and deliquescence of materials after contact with air;
- The exclusive airflow induced system prevents the sudden eruption of powder;
- The system is economical, simple, ready-to-use and free of installation and commissioning;
- The bulk density of the transport is up to 1300kg/m<sup>3</sup>, and the maximum siphon height is up to 5M.

# PARAMETER

Specification	Air Force (Mpa)	Bulk Density (g/cm <sup>3</sup> )	Capacity (KG/h)	Vacuum Degree(Mpa)	Air Consumption(m <sup>3</sup> /min)
PDSK 25	0.1-0.85	0.08-1.3	0-900	0.045	0.8max
PDSK 40	0.1-0.85	0.08-1.3	0-2500	0.05	1.2max
PDSK 50	0.1-0.85	0.08-1.3	0-3500	0.05	2.0max
PDSK 80	0.1-0.85	0.08-1.3	0-5500	0.055	4.0max

## Features of Powder ● ● ●

The fluidity, granularity and dispersivity of the powder are different, and they are very different from the gas and liquid.

Powder pump conveying powder and granular material are two phase flow technology, which can only be estimated by semi qualitative and semi quantitative method and experience from the past.

If the conditions are available, it is suggested that the actual test on the spot should be determined.



## TECHNICAL SERVICE

A、 When the pump fails, we will respond within 12 hours.

B、 After-Service Sites

**Head office: Skylink Fluid Technology Limited After-service Department**

Address: No.438, Jinyuan No.8 Road, Jiading District, Shanghai Tell: +86-021-62433309

**Guangzhou Office After-service:**

Address: 201Room, North Block Tianrun Building, Whampoa Road No.259, Tianhe District, Guangzhou

# POWDER PUMP

## SKYLINK Pneumatic Diaphragm Pump

### INSTALLATION DIMENSIONS

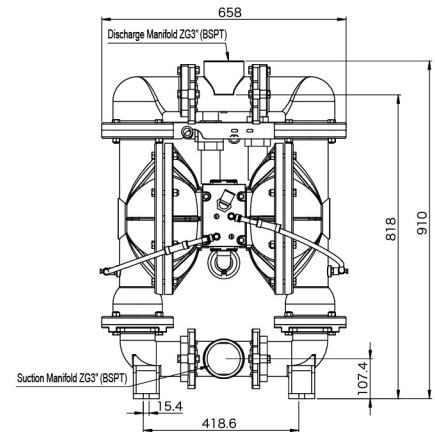
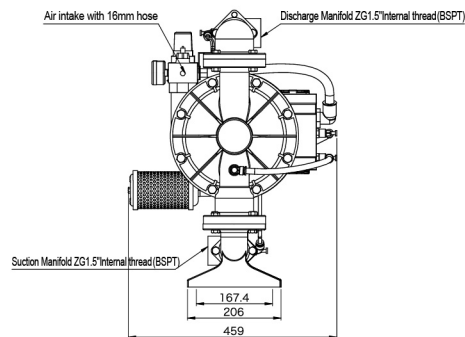
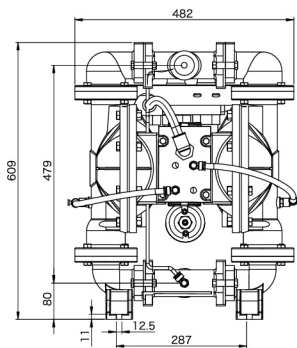

**PDSK 40**

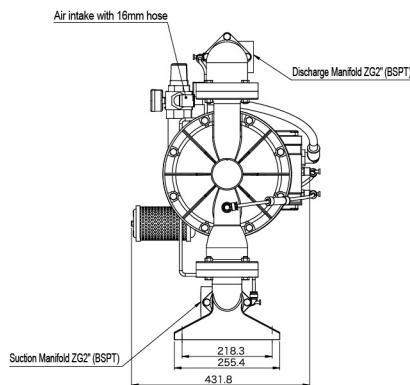
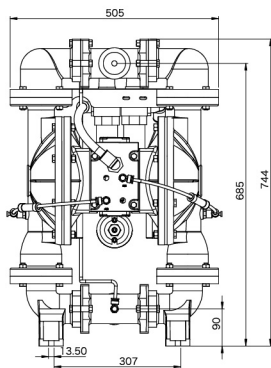

**PDSK 50**

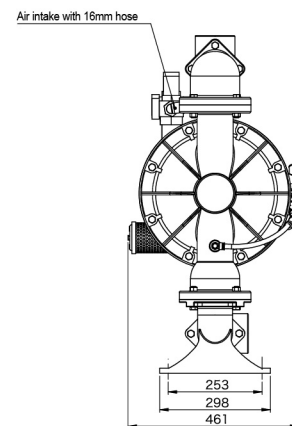

**PDSK 80**

Skylink Fluid Process Technology (Shanghai) Co., Ltd.  
Address: No. 438, Jinyuan No.8 Road, Jiading District, Shanghai

Shanghai Office : T: +86 (21)6243 3309 F: +86 (21)6257 0492  
Hong Kong Office : T: +852 3519 7783 F: +852 3519 2583  
Guangzhou Office: T: +86 (20)8552 9895 F: +86 (20)8554 4186  
Tianjin Office : T: +86 (22)2375 5918 F: +86 (22)2375 5918  
Wuxi Office : T: +86 (510)8284 4828 F: +86 (510)8284 4828

Copyright 2017 SKYLINK Corporation. All rights reserved.  
The product is manufactured under ISO9001 certified quality system.

Subject to modification without prior notice due to continuous product improvement.

"Skylink" is trademark of skylink fluid technology.

Issued: 07/2017 Copyright © 2017 SKYLINK Corporation

**Specialist in Fluid Transfer**